

Data sheet - Camera SPE-MG-104

Reference : SPE-MG-104

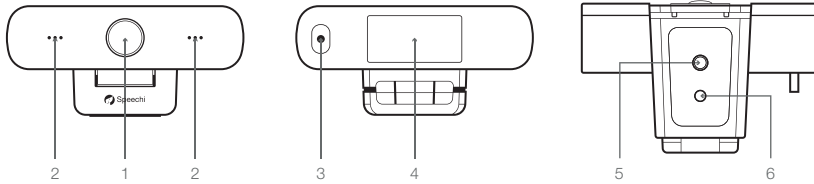

1. Lens (fixed focal length)
2. Audio IN
3. USB 2.0 cable
4. Fixation clamp
5. Screw hole (for tripod)
6. Screw hole (for bracket)

Dimensions (unit : mm)

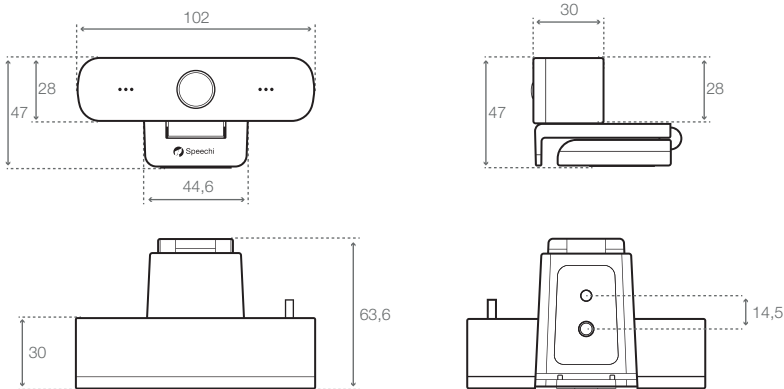

Main product features

- FHD: High quality sensor. Resolution up to 1920x1080, frame rate up to 30 fps.
- Multiple positioning: free to choose the installation position, the camera has a fixed clamp that allows it to be installed on an LCD monitor, on top of a laptop or directly on a desk with a tripod.
- Wide range of applications: personal video platform, video conferencing, collaborative office, etc.
- Easy to use: No need to download additional drivers or software, it is convenient and easy for users.
- USB 2.0 interface: Easy plug and play that allows for power support and upgrades.
- Optional multiple lenses: 80° horizontal viewing angle without distortion and 109° super wide angle lens.
- Stereo sound: built-in microphone, clear and natural stereo sound effect no need for an external microphone.
- Multiple video encoding (H264, H265, MJPEG, YUY2).